



VIPER™ HIGH OUTPUT FROZEN

4 FLAVOR FROZEN DISPENSER



Our 40+ years of expertise makes Viper the most intelligent, innovative and reliable frozen beverage dispenser in the world.

VIPER MAXIMIZES UPTIME, SALES AND PROFITS

Optimized refrigeration design – Boost sales and profits with industry leading capacity to meet peak demand while maintaining drink quality

C3 Technology – Provides unmatched drink profile consistency, builds repeat sales and minimizes syrup usage

Intelligent Defrost™ – Adaptive defrost allows you to make every sale with equipment that is always ready-to-serve

Flexible product delivery system – Sell the drinks consumers want today and in the future with incomparable individual barrel flexibility (FCB/FUB) and profile settings

Robust design and solid-state controls – Common field issues are resolved

VIPER IS ECO-FRIENDLY AND MINIMIZES OPERATING COSTS

Energy consumption – Best-in-class energy use

Programmable sleep mode – Conserves energy in off hours

LED lighting – Eliminates lost sales due to lights out and costly bulb replacements

Technician designed – Reduced maintenance and service times

MODELS

PART NUMBER	DESCRIPTION
621460142	Viper 4 flavor unit, 230/60Hz, air cooled, SPH valves, stainless steel panels, tall merchandiser
621460042	Viper 4 flavor unit, 230/60Hz, air cooled, Motorman valves, stainless steel panels, tall merchandiser
621460141	Viper 4 flavor unit, 230/60Hz, air cooled, SPH valves, stainless steel panels, short merchandiser
621460041	Viper 4 flavor unit, 230/60Hz, air cooled, Motorman valves, stainless steel panels, short merchandiser

SPH stands for Stainless Pull Handle. For FUB applications, Motorman valves are recommended.

ACCESSORIES

PART NUMBER	DESCRIPTION
629087406	Leg kit, 4" legs adjustable to 5.25"
620046556	Viper 4 flavor cart, stainless steel
620046477	Viper 4 flavor generic graphic for tall merchandiser
620047323	Viper 4 flavor generic graphic for short merchandiser
620042868	Generic flavor card set (includes 18 flavors)

Refer to installation accessory guideline for complete list.

TECHNICAL SPECIFICATIONS:

ELECTRICAL RATINGS 230V +/- 15V 60Hz, 30a, single phase
(includes 8ft. power cord NEMA L6-30P molded plug connection)

PRESSURE REQUIREMENTS . . . CO2 = 75 psig
Water = 25 min. psig dynamic

DRAW CAPACITY 75 oz/min. continuous, alternating barrels @ 75°F ambient

REFRIGERATION 19,000 BTU, R404A

MINIMUM CLEARANCE REQUIRED Top: 12"
Each side: 2" or Back: 2"
NOTE: Temperature above 100°F requires additional clearance

UNIT DIMENSIONS 29"W x 32.5"D x 43.7"H (tall merchandiser)
29"W x 32.5"D x 37"H (short merchandiser)

MERCHANDISER DIMENSIONS . . 28.7"W x 18.75"H (tall merchandiser)
28.7"W x 11.79"H (short merchandiser)

FLAVOR CARD DIMENSIONS . . . 6.5"W x 4"H

SHIPPING WEIGHT 500 lbs; cart 200 lbs

AGENCY LISTINGS  

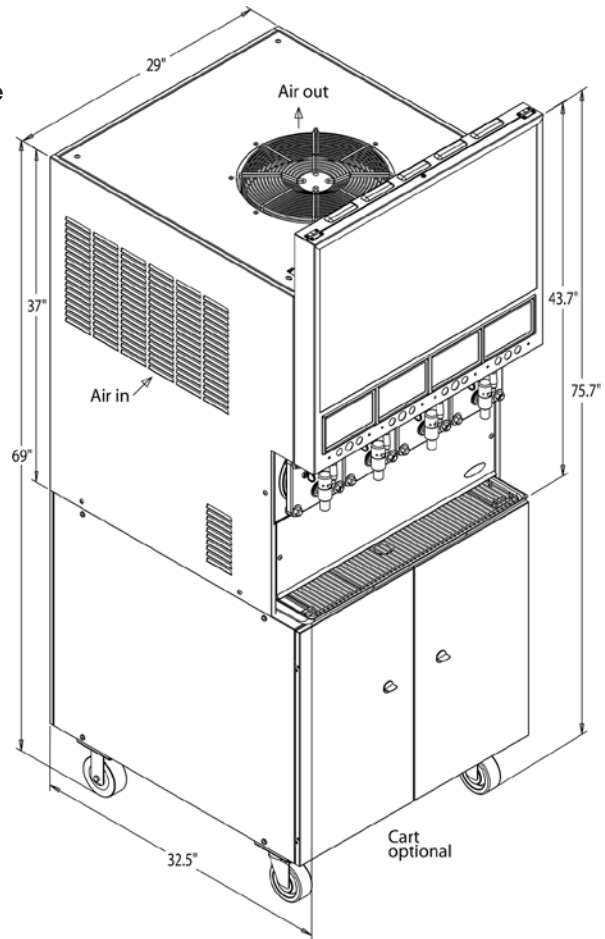

IN THE U.S.A.
Ph: 800.238.3600
Fax: 763.488.4283

OUTSIDE THE U.S.A.
Ph: 763.488.8200
Fax: 763.488.4283

101 Broadway Street West
Osseo, MN 55369
www.cornelius.com