



Series 200

Self-Contained Flake Ice Machine



Features:

- Great performance
- Quality flake ice
- Production up to 200 lbs. (91 kgs.) per day
- Bin Capacity 75 lbs. (34 kgs.)
- Environmentally safe
- R404a Refrigerant
- Energy efficient - lower cost - long life
- Continuous ice making
- One single moving part
- Top mounted drive system
- Compact space saving design
- Low profile
- Requires only 4 sq. ft.
- Gray baked enamel exterior or optional stainless steel
- Polyethylene bin



Series 200

Technical Specifications:

Condenser: Air-cooled

Circuit Capacity: 15A

Maximum fuse size: 5A

Operating Weight: 190 lbs. (86 kgs.)

Ice Storage Capacity: 75 lbs. (34 kgs.)

Refrigerant type: R-404av

Ambient temperature: 50°F (10°C) -100°F (38°C)

Shipping Weight: 220 lbs. (100 kgs.)

Water temperature: 50°F/10°C - 90°F/32°C

Water pressure: 20-120 psi

Agency Listings:

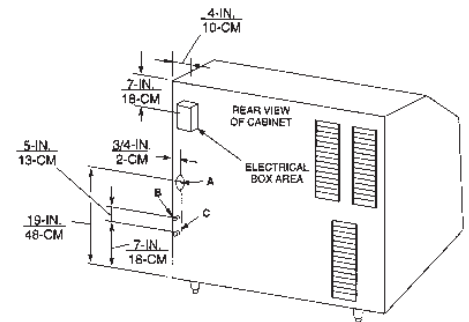
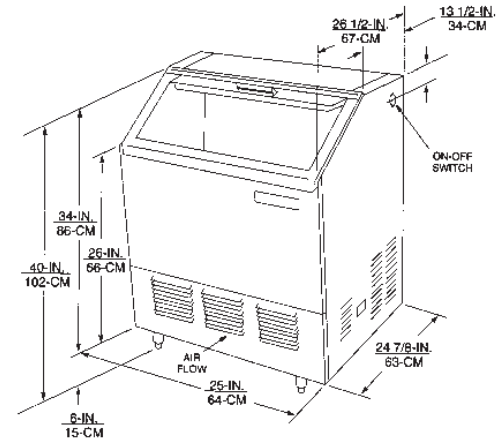

A – 1/4 WATER INLETS (S.A.E. MALE FLARE)
 B – 5/8 O.D. TUBE (DRAIN)
 C – 1/2 O.D. TUBE (DRAIN)

AF-200-P(S)-SCR PRODUCTION CHART			
AIR TEMPERATURE	WATER TEMPERATURE		
	50°F/10°C	70°F/21°C	80°F/27°C
50°F/10°C	219 lbs./99 kgs.	188 lbs./85 kgs.	175 lbs./79 kgs.
70°F/21°C	208 lbs./95 kgs.	174 lbs./79 kgs.	166 lbs./75 kgs.
90°F/32°C	161 lbs./35 kgs.	130 lbs./59 kgs.	117 lbs./53 kgs.

AF-200-P-SC50R PRODUCTION CHART			
AIR TEMPERATURE	WATER TEMPERATURE		
	50°F/10°C	70°F/21°C	80°F/27°C
50°F/10°C	234 lbs./106 kgs.	206 lbs./94 kgs.	197 lbs./90 kgs.
70°F/21°C	213 lbs./97 kgs.	190 lbs./86 kgs.	180 lbs./82 kgs.
90°F/32°C	183 lbs./83 kgs.	164 lbs./75 kgs.	156 lbs./71 kgs.

Model No.	Description	Cabinet	Electrical	Voltage
AF200-P-SCR	200 Self-Contained Flaker	Enamel	115V/60Hz/1	110-126V
AF200-S-SCR	200 Self-Contained Flaker	Stainless	115V/60Hz/1	110-126V
AF200P-SC50R	200 Self-Contained Flaker	Enamel	220V/50Hz/1	209-264V



For more information or to place an order, contact your sales representative or authorized distributor.

In the US:
 Phone: 1-800-238-3600
 Fax: 1-800-535-4235
Outside the US:
 Phone: 1-763-421-6120
 Fax: 1-763-422-3297

IMI Cornelius Inc.
 One Cornelius Place
 Anoka, MN 55303-6234
 USA