



Universal 750

Pre-Mix Beverage Dispenser



Features:

- Cornelius ice bank design maintains finished drink temperature below 40°F during high volume periods
- Embossed metal cabinet
- Efficient copper evaporator
- Fully insulated water bath
- Environmentally friendly 134A refrigeration system
- Wheel and push bar kit standard
- Product lines enter through top rear of unit
- Top mounted ice bank control is easily accessible
- Lid is hinged and latched – no more lost lids



Universal 750

Technical Specifications:

Cooling Capacity:

586 six oz. drinks below 38°F @ 4/min. in 75°F ambient
294 six oz. drinks below 38°F @ 6/min. in 90°F ambient

Compressor: 1/3 h.p.

Condenser Finish: Black painted

Cup Clearance: 6 3/4"

Electrical Rating: 115V / 60Hz / 6.7A, 230 / 50Hz / 4.0A

Initial Average Icebank: 46#

Refrigerant: R134-a

IPD@70°F: 6.5 hrs.

Shipping Weight: 159 lbs. (72 kgs.)

Valve Types: Self closing pre-mix

Agency Listings:

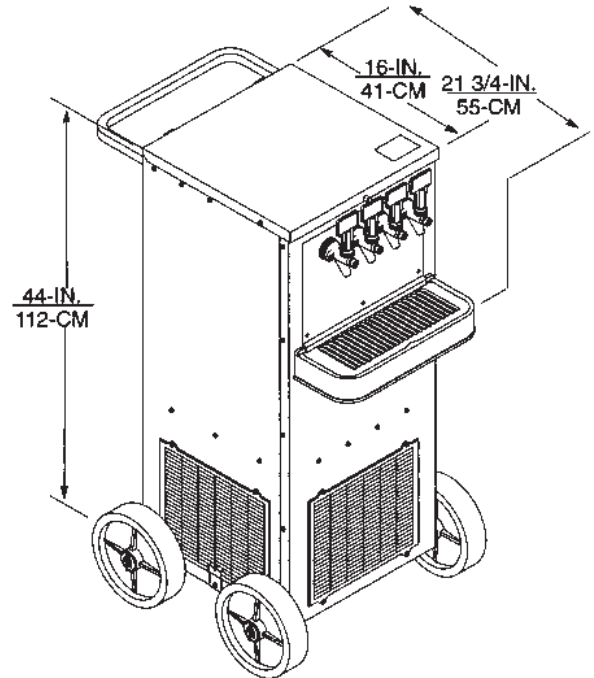

Part No.	Description
284994	Four product 750 w/wheels and push bar
284995	Five product 750 w/wheels and push bar
186859-044	Locking valve cover with padlock, four product
186855-044	Locking valve cover with padlock, five product
494994	230/50 Four product 750 w/wheels and push bar
494995	230/50 Five product 750 w/wheels and push bar



For more information or to place an order, contact your sales representative or authorized distributor.

In the US:

Phone: 1-800-238-3600

Fax: 1-800-535-4235

Outside the US:

Phone: 1-763-421-6120

Fax: 1-763-422-3297

IMI Cornelius Inc.

One Cornelius Place
Anoka, MN 55303-6234
USA