



Beverage Dispenser

Post-Mix



Features:

- One, two, or four flavor capability
- Inlet line access from back or bottom of tower
- Drip tray can be removable or plumbed
- Cooling capacity relies on your choice of remote cooling unit
- Syrup is stored in remote containers
- Simple connections to water and syrup lines
- Brix ratio adjustable from 5:1 to 8.5:1
- Electric or mechanical valves available
- Stainless steel construction



Beverage Dispenser

Technical Specifications:

Cup Clearance: 9 3/4" (25 cm)

Electrical Rating: 24VAC. / 50-60 Hz. (if applicable)

Water Pressure Requirement: 25 lbs. psi minimum

Agency Listings:

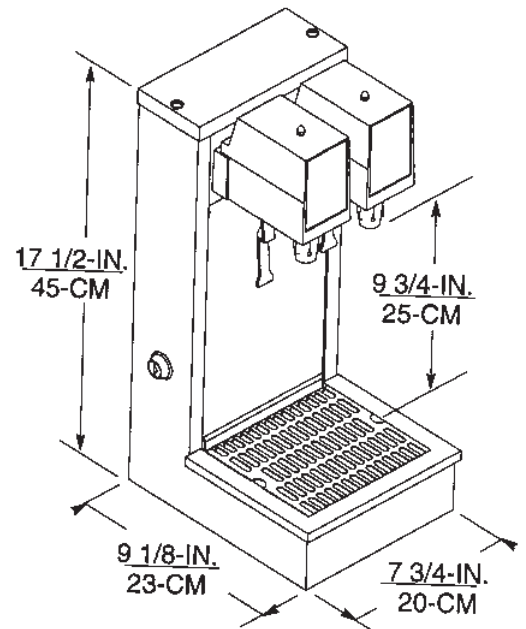
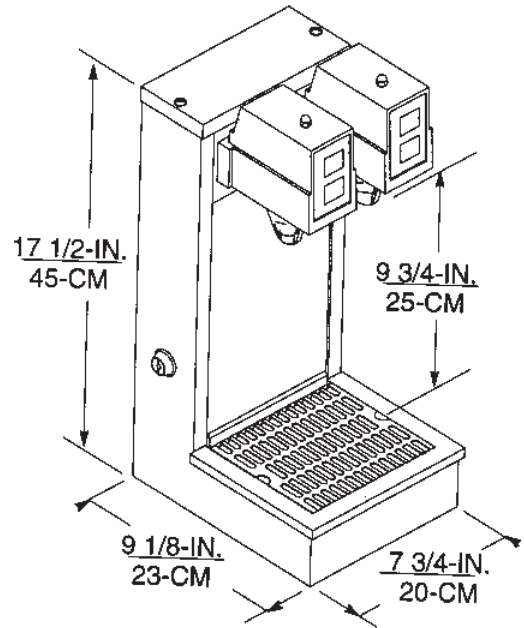

Part No.	Description	Shipping Weight
41-4011-132	Single Valve Dispenser, Mechanical Valve	9 lbs. (4 kgs.)
41-4012-132	Two Valve Dispenser, Mechanical Valve	10 lbs. (4.5 kgs.)
41-4013-132	Single Valve Dispenser, Electric Valve SF-1	14 lbs. (6.4 kgs.)
41-4014-132	Two Valve Dispenser, Electric Valve SF-1	14 lbs. (6.4 kgs.)
41-4015-132	Two Valve Four Flavor Dispenser, Electric Valve	14 lbs. (6.4 kgs.)
631000013	Two Valve Dispenser, Electric Valve UF-1	14 lbs. (6.4 kgs.)
631000014	Single Valve Dispenser, Electric Valve UF-1	14 lbs. (6.4 kgs.)



For more information or to place an order, contact your sales representative or authorized distributor.

In the US:

Phone: 1-800-238-3600

Fax: 1-800-535-4235

Outside the US:

Phone: 1-763-421-6120

Fax: 1-763-422-3297

IMI Cornelius Inc.

One Cornelius Place
Anoka, MN 55303-6234
USA