



# Super Astra

Super Astra



## Features:

- Chilled water recirculation eliminates high casual drink temperatures
- High capacity unit, fast recovery, efficient 1/2 h.p. compressor
- Low profile, can fit under the counter
- Different configurations, supports stand alone space saving tower configurations for dispensing non-carbonated beverages



# Super Astra

## Technical Specifications:

**Compressor:** 1/2 H.P.

**Ice Bank Weight:** 20 lbs. (9 kgs.)

**Refrigerant:** R-134A

**Condenser:** Air

**Evaporator:** Copper

**Water Bath Capacity:** 3 gallons (11.36 liters)

**Product Coils:** 2 (1/4" I.D.)

**Maximum Cooling Capacity:** 110 (figure represents number of 12 oz. drinks that can be served below 45°F at 2 drinks per minute, assuming an inlet product temperature of 75°F)

**Electrical Requirements:** 115V / 60Hz / 7.2A

**Shipping Weight:** 76 lbs. (35 kgs.)

**Agency Listings:**

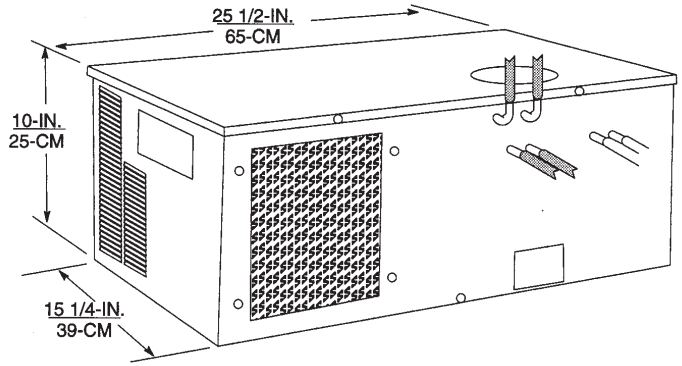

Part No.	Description
481860052	Super Astra
0473	Six line python kit
414014132	Two flavor tea tower (electric valves)
414015132	Four flavor tea tower (Gemini valves)



For more information or to place an order, contact your sales representative or authorized distributor.  
[www.cornelius.com](http://www.cornelius.com)

**In the US:**  
Phone: 1-800-238-3600  
Fax: 1-800-535-4235  
**Outside the US:**  
Phone: 1-763-421-6120  
Fax: 1-763-422-3297

**IMI Cornelius Inc.**  
One Cornelius Place  
Anoka, MN 55303-6234  
USA