



# QUEST 2000

Two-Flavor, Post-Mix Juice Dispenser



## FEATURES

- Improved refrigeration system with solid-state ice bank control
- Large-capacity ice bank greatly improves draw performance, providing more cold drinks during peak demand
- Frost-free refrigeration compartment conveniently accommodates various juice packaging containers
- Narrow foot print conserves counter space
- State-of-the-art lighted merchandiser promotes impulse sales and brand recognition
- Contemporary styling is a combination of attractive gray plastic and sturdy stainless steel
- Modular component design simplifies service and sanitation
- Push button or portion control dispensing is available



## SPECIFICATIONS

### DESCRIPTION

Model Quest

- 115 volts, 60 Hz
- 230 volts, 50 Hz

### REFRIGERATION

- Hermetically sealed system
- R-134a refrigerant 6.2 oz (175 g)
- Ice bank is 8 lb

### CABINETRY

High impact plastic cabinetry with stainless steel front panel

### DISPENSER DIMENSIONS

Height .....29.3" (74.4 cm)  
Width .....10.4" (26.4 cm)  
Depth .....24.3" (61.7 cm)

### WEIGHT

Dry weight .....96 lb (43.5 kg)  
Operating weight .....136 lb (61.7 kg)  
Shipping weight .....120 lb (54.4 kg)

### RECOMMENDED CLEARANCE

4" (10.16 cm) in back, 12" (30.48 cm) on top

### WATER CONNECTION

3/8" (.95 cm) SAE male flare SAE fitting on dispenser

### CONCENTRATE STORAGE

2 - 3.5 liter bottles

### WATER SUPPLY REQUIREMENTS

- Recommended dynamic operating pressure is 50 psi (3.4 bar)
- Maximum static pressure is 100 psi (6.9 bar)
- Minimum dynamic pressure is 30 psi (2.1 bar)

### COOLING

Quest can dispense four 5 oz drinks (148 ml) per minute, at 75°F (24°C) ambient, 75°F (24°C) incoming water, and 40°F (4°C) concentrate without exceeding a 40°F (4°C) drink temperature.

### FLOW RATE

Adjustable water flow rate from 1.0 oz/sec to 2.2 oz/sec

Handles 2 + 1 up to 7 + 1 concentrate

### OPTIONAL ACCESSORIES

Extended Leg Kit for Pitchers/Carafes

Portion Control Dispense

Refillable Concentrate Reservoir (2) 3.5 liters

### Agency listings

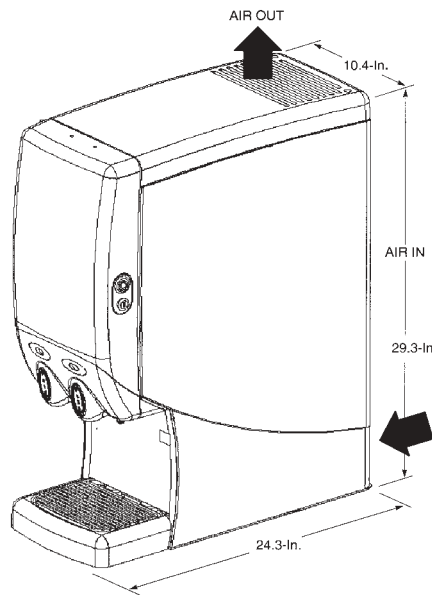

For more information or to place an order, contact your sales representative or authorized distributor.

#### In the US:

Phone: 1-800-238-3600

Fax: 1-800-535-4235

#### Outside the US:

Phone: 1-763-421-6120

Fax: 1-763-422-3297

#### IMI Cornelius Inc.

One Cornelius Place

Anoka, MN 55303-6234

USA