



MILLENNIUM II 6000

Six Flavor, Post-Mix Juice Dispenser



FEATURES

- Six product selection
- For use with closed container (B-I-B) juice packaging
- Unique mixing valve and nozzle provide a quality drink on every dispense, over a wide range of juice/drink concentrates
- Large capacity ice bank increases draw capacity, consistently pouring a cold drink
- Solid state ice bank control
- Easy-to-adjust brining system controls and maintains a consistent finished drink
- New contemporary cabinet design is a blend of attractive black plastic and sturdy stainless steel
- Completely self contained pumping system. No additional pumps or air supply needed.
- Lighted merchandiser is standard
- Push button or programmable portion controlled dispensing available

CATF 8678-01

J U I C E D I S P E N S E R



Millennium II 6000

SPECIFICATIONS

DESCRIPTION

- Model Millennium II 6000
- 115 volts, 60 Hz, 1 Phase, 11.1 amps
- Model Millennium II 6002
- 220 volts, 50 Hz, 1 Phase, 5.55 amps

REFRIGERATION

1/3 H.P., Hermetically sealed system
R-134A refrigerant

ICE BANK (25 LBS)

Initial pull down 5 hours

DISPENSER DIMENSIONS

Height 32.0" (81.5 cm)
Width 17.6" (45.0 cm)
Depth 26.2" (66.5 cm)

WEIGHT

Operating weight 220 lbs. (100 kg)
Shipping weight 140 lbs. (63.5 kg)

RECOMMENDED CLEARANCE

6" (16 cm) at side vents, 18" (46 cm) on top for air circulation

WATER CONNECTION

3/8" (.95 cm) SAE male flare fitting on dispenser

WATER SUPPLY REQUIREMENTS

- 100 psi (6.8 bar) maximum static pressure
- 20 psi (1.4 bar) minimum dynamic pressure

AGENCY LISTINGS

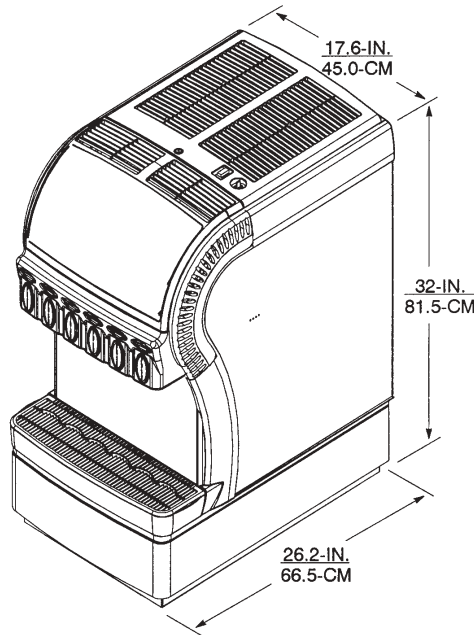

For more information or to place an order, contact your sales representative or authorized distributor.

In the US:
Phone: 1-800-238-3600
Fax: 1-800-535-4235
Outside the US:
Phone: 1-763-421-6120
Fax: 1-763-422-3297

IMI Cornelius Inc.
One Cornelius Place
Anoka, MN 55303-6234
USA