



# MILLENNIUM II 4000

Four-Flavor, Post-Mix Juice Dispenser



## Features

- Four product selection
- For use with closed container (B-I-B) juice packaging
- Unique mixing valve and nozzle provide a quality drink on every dispense, over a wide range of juice/drink concentrates
- Large capacity ice bank increases draw capacity, consistently pouring a cold drink
- Solid state ice bank control
- Easy-to-adjust brining system controls and maintains a consistent finished drink
- New contemporary cabinet design is a blend of attractive black plastic and sturdy stainless steel
- Completely self contained pumping system. No additional pumps or air supply needed.
- Lighted merchandiser is standard
- Push button or programmable portion controlled dispensing available

CATF 8677

J U I C E D I S P E N S E R



# Millennium II 4000

## SPECIFICATIONS

### DESCRIPTION

Model Millennium II 4000

- 115 volts, 60 Hz, 1 Phase, 6.1 amps

Model Millennium II 4002

- 220 volts, 50 Hz, 1 Phase, 3.0 amps

### REFRIGERATION

1/3 HP, Hermitically sealed system  
(198.4 g) 5.5 oz R-134A refrigerant

### ICE BANK (14 LBS)

Initial pulldown 4 hours, 30 minutes

### DISPENSER DIMENSIONS

Height .....32" (81.5 cm)  
 Width .....14.7" (37.5 cm)  
 Depth .....26.2" (66.5 cm)

### WEIGHT

Operating weight .....175 lbs. (79.4 kg)  
 Shipping weight .....110 lbs. (50 kg)

### RECOMMENDED CLEARANCE

6" (16 cm) at side vents, 18" (46 cm) on top for air circulation

### WATER CONNECTION

3/8" (.95 cm) SAE male flare fitting on dispenser

### WATER SUPPLY REQUIREMENTS

- 100 psi (6.8 bar) maximum static pressure
- 20 psi (1.4 bar) minimum dynamic pressure

### AGENCY LISTINGS

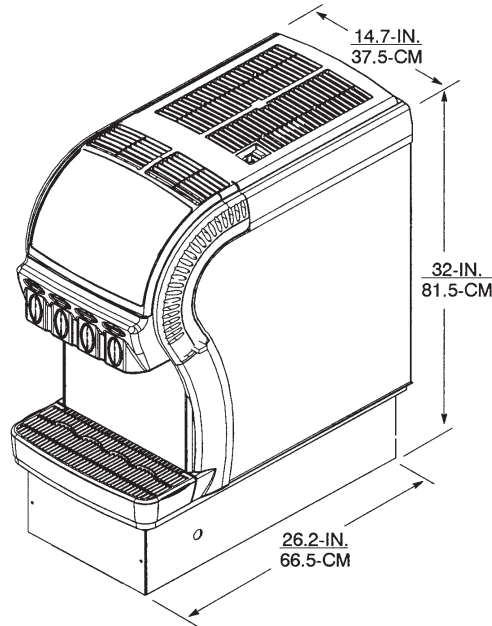

For more information or to place an order, contact your sales representative or authorized distributor.

#### In the US:

Phone: 1-800-238-3600

Fax: 1-800-535-4235

#### Outside the US:

Phone: 1-763-421-6120

Fax: 1-763-422-3297

#### IMI Cornelius Inc.

One Cornelius Place

Anoka, MN 55303-6234

USA