



Carbonator

Low Profile Large Reserve Carbonator



Features:

- 2 1/2 gallon carbonated water reserve tank
- Low voltage, solid state, liquid level control
- Check valve protects against water entering CO₂ supply system
- Double ball check protects against carbonated water backing up into water supply
- Thermal protector on pump minimizes pump burn out due to lack of water
- Rubber feet for quiet operation
- Available with “Vent to Atmosphere” check valve upon request



Carbonator

Technical Specifications:

Width: 15 1/2" (39cm)

Depth: 11 1/4" (29cm)

Height: 16 1/8" (41cm)

Carbonator Motor: 1/3 H.P.

Carbonator Pump: 100 GPH

Operating Pressure: 125 psi maximum

Inlet Connections: 3/8"

Soda Water Outlet Connections (2): 3/8" (9.525 mm)

Electrical Requirements:

115V / 50Hz or 60Hz / 7.2A 230V / 50Hz / 3.6A

Shipping Weight: 30 lbs. (14 kgs.)

Agency Listings:

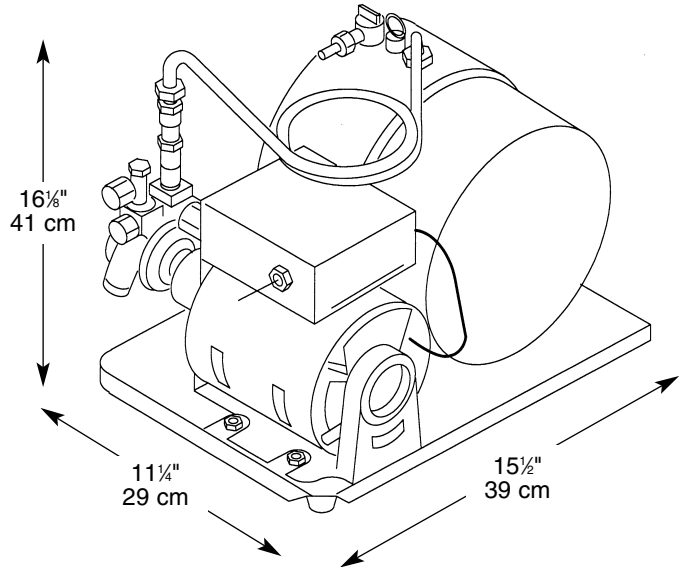

Part No.	Description
416424XXX	Low profile large reserve carbonator specify configuration, 115V / 50Hz or 60Hz
1624	Low profile large reserve carbonator with vent to atmosphere check valve, 115V / 50Hz or 60Hz
496424000	Low profile large reserve carbonator, 230V / 50Hz



For more information or to place an order, contact your sales representative or authorized distributor.

In the US:

Phone: 1-800-238-3600

Fax: 1-800-535-4235

Outside the US:

Phone: 1-612-421-6120

Fax: 1-612-422-3297

IMI Cornelius Inc.

One Cornelius Place
Anoka, MN 55303-6234
USA