



# Impulse™ Juice

## Post-Mix Non-Carbonated Beverage Dispenser



### Features:

- Accepts a variety of merchandising messages
- Designed for performance, reliability, and easy serviceability
- For ease of service and greater inventory efficiencies, the Impulse line has common components across all units, around the world
- Critical components such as the valves and ice bank control are easily accessible for service



# Impulse™ Juice

## Technical Specifications:

Type of valves: UFJ 3 oz. (88.8 ml/second Post-Mix Lever)

Number of valves: 6

Optional number of non carb valves:

Refrigerant: R-134a

Electrical Requirements: 120V/ 60Hz

Continuous drink capacity (12oz (355ml) drinks per minute @ 75°F (24°C) ambient): 2.5

Peak drink capacity (12oz (355ml) drinks per minute @ 75°F (24°C) ambient): 217

Cup Clearance: 10.25 in (260 mm)

Compressor: 1/3 hp

Water Bath Size: 17 gal (64.4 litres)

Ice Bank Size: 30 lb (13.6 kg)

Shipping Weight: 124 lb (56 kg)

## Agency Listings:

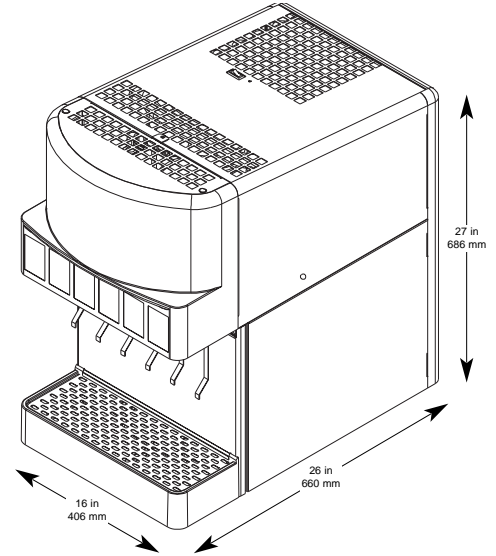

Part No.	Description
851000319	Impulse 1 6 Flavor UFJ Lever Unlighted
851000320	Impulse 1 6 Flavor UFJ Lever Lighted



For more information or to place an order, contact your sales representative or authorized distributor.  
[www.cornelius.com](http://www.cornelius.com)

**In the US:**  
Phone: 1-800-238-3600  
Fax: 1-800-258-0255  
**Outside the US:**  
Phone: 1-763-421-6120  
Fax: 1-763-422-3297

**IMI Cornelius Inc.**  
One Cornelius Place  
Anoka, MN 55303-6234  
USA