



# Chest-A-Field

Dispensing Chest



## Features:

- Increase brand visibility at special event sites
- Simplifies and standardizes your dispense set-up. Frees time for dispensing drinks and satisfying customers
- Greater durability means extended equipment life (rust and corrosion proof)
- Provides consistent placement of decals, making it easier for the consumer to order their favorite beverage
- Helps keep the beverage dispenser area clean and hassle-free
- Environmentally friendly design that also maximizes cold containment



# Chest-A-Field

## Technical Specifications:

Shipping Weight: 68 lbs. (31 kgs.)

Ice Capacity: 45 lbs. (20 kgs.)

### Agency Listings:

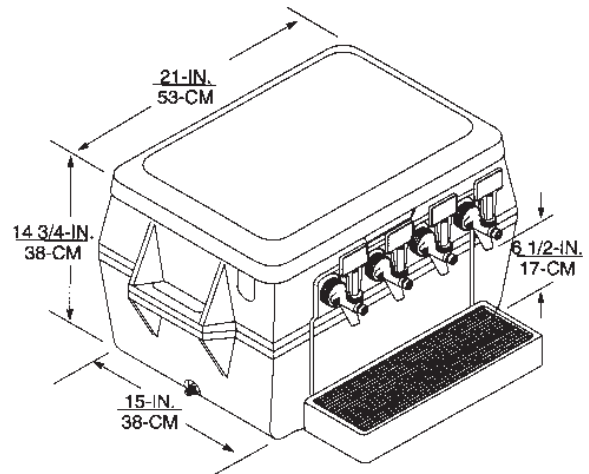
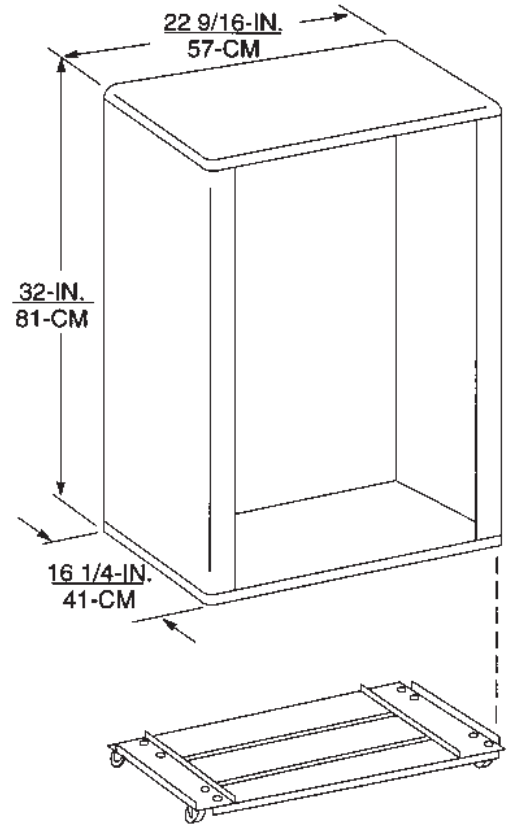

Part No.	Description
264404040	Grey Chest-A-Field
264365069	Optional stand for Chest-A-Field
160367000	Optional 12 x 18 caster kit



For more information or to place an order, contact your sales representative or authorized distributor.

#### In the US:

Phone: 1-800-238-3600

Fax: 1-800-535-4235

#### Outside the US:

Phone: 1-763-421-6120

Fax: 1-763-422-3297

#### IMI Cornelius Inc.

One Cornelius Place  
Anoka, MN 55303-6234  
USA